

PLAN VIEW

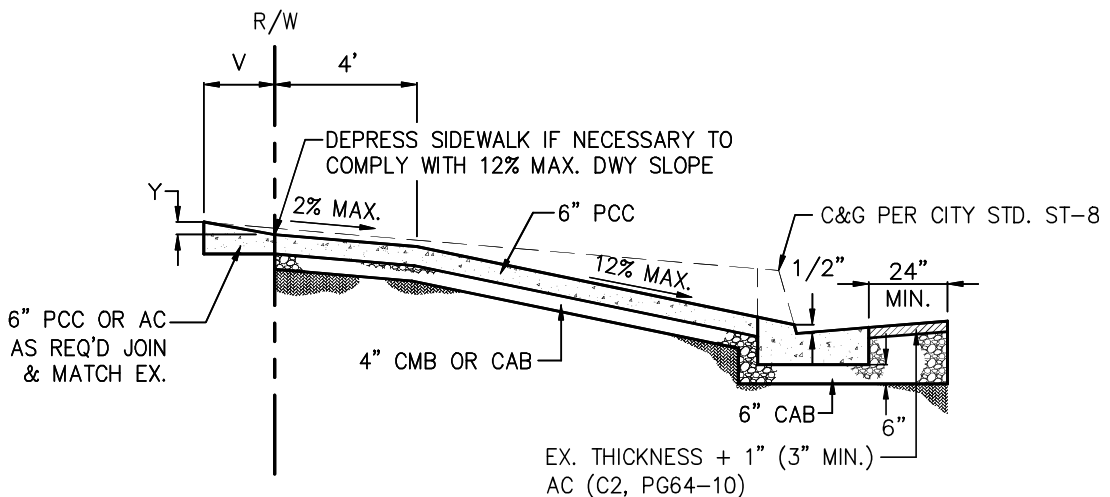

SECTION A-A

NOTES:

1. ALL CONSTRUCTION SHALL BE IN CONFORMANCE WITH THE "SPPWC" LATEST EDITION.
2. PCC SHALL BE 520-C-2500 PER "SPPWC" LATEST EDITION.
3. CAB AND CMB TO 95 % RELATIVE COMPACTION AND 90 % SUBGRADE.
4. EXISTING CONCRETE SHALL BE REMOVED TO THE NEAREST SCOREMARK.
5. DRIVEWAY INSTALLATION SHALL BE IN CONFORMANCE WITH THE DRIVEWAY POLICY OF THE DEPARTMENT OF PUBLIC WORKS (ST-1).
6. COARSE BROOM FINISH ON DRIVEWAY AND FINE HAIR BROOM FINISH ON SIDEWALK.
7. "W"=12' MIN. & 35' MAX. (OR AS APPROVED) AND "X"=3' MIN.
8. "V" DIMENSION SHALL BE 2' MIN. & ESTABLISHED IN FIELD BASED ON "Y" DEPTH REQUIRED (Y=0.30' MAX., ADJUST TO MATCH FIELD CONDITIONS).
9. ASPHALT AND CONCRETE TO BE REMOVED SHALL BE SAWCUT.
10. PLACE WEAKENED PLANE JOINTS (WPJ) EVENLY SPACED AT 10' O.C. MAX.
11. WIDTH OF 24" OF AC/AB TO BE R&R WHEN REPLACING C&G PORTION OF DRIVEWAY.

DWG NTS

<p>CITY OF GARDENA DEPARTMENT OF PUBLIC WORKS</p>	<p>APP. BY: <i>Allan Rigg</i> 9/16/2024</p> <p style="text-align: center;">CITY ENGINEER DATE</p>										
<p>TITLE: COMMERCIAL DRIVEWAY (TYPE A)</p>	<table border="1" style="width: 100%; border-collapse: collapse;"> <tr> <td style="width: 33%;">DESIGNED BY</td> <td style="width: 16.5%;">KK</td> <td style="width: 16.5%;">09/24</td> <td rowspan="3" style="width: 34%; text-align: center; vertical-align: middle;">DWG. NO. ST-2</td> </tr> <tr> <td>DRAWN BY</td> <td>KK</td> <td>09/24</td> </tr> <tr> <td>CHECKED BY</td> <td>KK</td> <td>09/24</td> </tr> </table>	DESIGNED BY	KK	09/24	DWG. NO. ST-2	DRAWN BY	KK	09/24	CHECKED BY	KK	09/24
DESIGNED BY	KK	09/24	DWG. NO. ST-2								
DRAWN BY	KK	09/24									
CHECKED BY	KK	09/24									