

PLAN VIEW

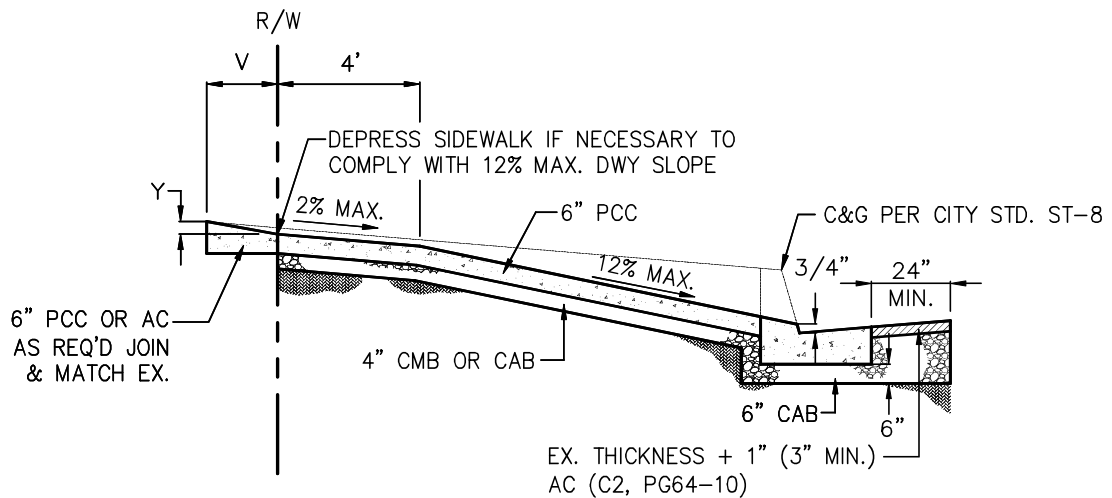

SECTION A-A

NOTES:

1. ALL CONSTRUCTION SHALL BE IN CONFORMANCE WITH THE "SPPWC" LATEST EDITION.
2. PCC SHALL BE 520-C-2500 PER "SPPWC" LATEST EDITION.
3. ASPHALT AND CONCRETE TO BE REMOVED SHALL BE SAWCUT.
4. EXISTING CONCRETE SHALL BE REMOVED TO THE NEAREST SCOREMARK.
5. PLACE WEAKENED PLANE JOINTS (WPJ) EVENLY SPACED AT 10' O.C. MAX.
6. DRIVEWAY INSTALLATION SHALL BE IN CONFORMANCE WITH THE DRIVEWAY POLICY OF THE DEPARTMENT OF PUBLIC WORKS (ST-1).
7. CAB AND CMB TO 95 % RELATIVE COMPACTION AND 90 % SUBGRADE.
8. COARSE BROOM FINISH ON DRIVEWAY AND FINE HAIR BROOM FINISH ON SIDEWALK.
9. "W"=12' MIN. & 35' MAX. (OR AS APPROVED).
10. "V" DIMENSION SHALL BE 2' MIN. & ESTABLISHED IN FIELD BASED ON "Y" DEPTH REQUIRED (Y=0.30' MAX., ADJUST TO MATCH FIELD CONDITIONS).
11. 24" OF ASPHALT TO BE R&R WHEN REPLACING C&G PORTION OF DRIVEWAY.

DWG NTS

**CITY OF GARDENA
DEPARTMENT OF PUBLIC WORKS**

APP. BY:

Allan Rigg

9/16/2024

CITY ENGINEER

DATE

TITLE:

**COMMERCIAL DRIVEWAY
(TYPE B)**

DESIGNED BY	KK	09/24
DRAWN BY	KK	09/24
CHECKED BY	KK	09/24

DWG. NO. ST-3