

**PLAN VIEW**

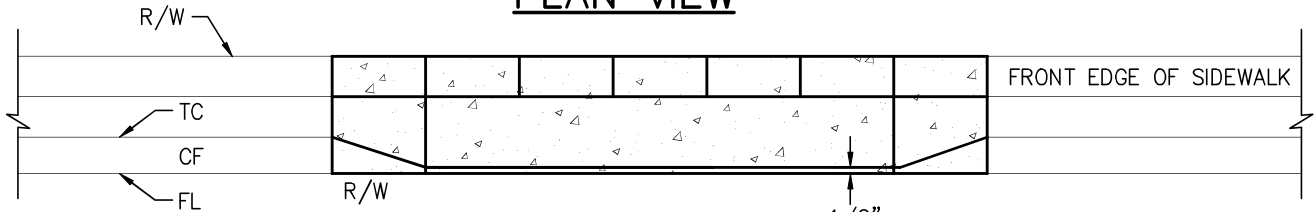

**ELEVATION VIEW**

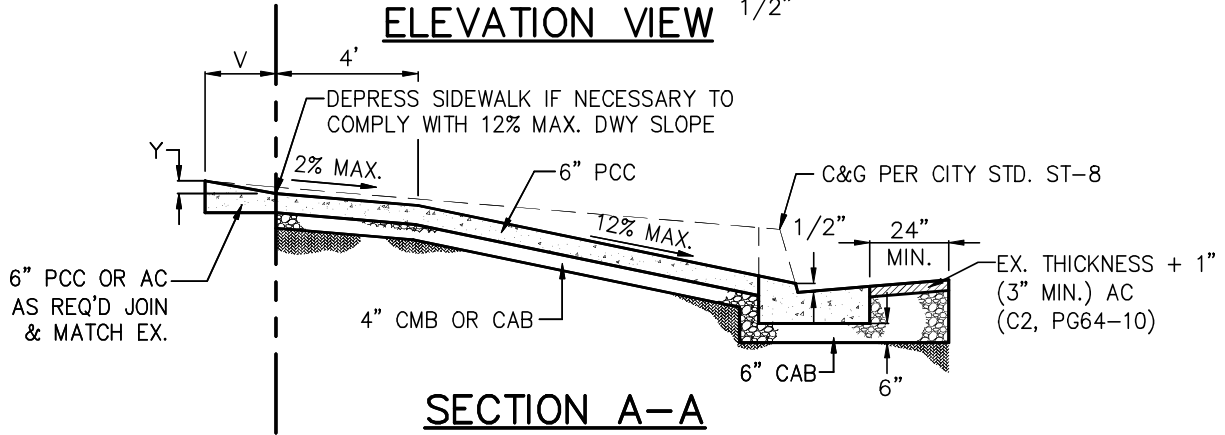

**SECTION A-A**

**NOTES:**

1. ALL CONSTRUCTION SHALL BE IN CONFORMANCE WITH THE "SPPWC" LATEST EDITION.
2. PCC SHALL BE 520-C-2500 PER "SPPWC" LATEST EDITION.
3. ASPHALT AND CONCRETE TO BE REMOVED SHALL BE SAWCUT.
4. EX. CONCRETE SHALL BE REMOVED TO THE NEAREST SCOREMARK.
5. PLACE WEAKENED PLANE JOINTS (WPJ) EVENLY SPACED AT 10' O.C. MAX.
6. DWY INSTALLATION SHALL BE IN CONFORMANCE WITH THE DWY POLICY OF THE DEPARTMENT OF PUBLIC WORKS (ST-1).
7. CAB AND CMB TO 95% RELATIVE COMPACTION AND 90% SUBGRADE.
8. COARSE BROOM FINISH ON DRIVEWAY AND FINE HAIR BROOM FINISH ON SIDEWALK.
9. "W"=10' MIN. & 35' MAX. (OR AS APPROVED) AND "X"=3' MIN.
10. "V" DIMENSION SHALL BE 2' MIN. & ESTABLISHED IN FIELD BASED ON "Y" DEPTH REQUIRED (Y=0.30' MAX., ADJUST TO MATCH FIELD CONDITIONS).
11. MIN. 20' OF FULL HEIGHT CURB REQUIRED BETWEEN DRIVEWAYS SERVING THE SAME LOT.
12. SAWCUT EXISTING CURB AT TOP OF "X" FOR JOIN.
13. IT MAY BE NECESSARY FOR APPROACH TO EXTEND ONTO PRIVATE PROPERTY TO INSURE 12% MAX. DRIVEWAY GRADE.
14. 24" OF ASPHALT TO BE R&R WHEN REPLACING C&G PORTION OF DRIVEWAY.

**DWG NTS**

|  |   |             |                           |       |                           |          |    |       |            |    |       |
|--|---|-------------|---------------------------|-------|---------------------------|----------|----|-------|------------|----|-------|
| <p><b>CITY OF GARDENA</b><br/><b>DEPARTMENT OF PUBLIC WORKS</b></p>                            | <p>APP. BY: <i>Allan Rigg</i>      9/16/2024</p> <p style="text-align: center;">CITY ENGINEER      DATE</p>   |             |                           |       |                           |          |    |       |            |    |       |
| <p>TITLE:</p> <p style="text-align: center; font-size: 1.2em;"><b>RESIDENTIAL DRIVEWAY</b></p> | <table border="1" style="width: 100%; border-collapse: collapse;"> <tr> <td style="width: 33%;">DESIGNED BY</td> <td style="width: 16.5%;">KK</td> <td style="width: 16.5%;">09/24</td> <td rowspan="3" style="width: 34%; text-align: center; vertical-align: middle;"><b>DWG. NO.      ST-4</b></td> </tr> <tr> <td>DRAWN BY</td> <td>KK</td> <td>09/24</td> </tr> <tr> <td>CHECKED BY</td> <td>KK</td> <td>09/24</td> </tr> </table> | DESIGNED BY | KK                        | 09/24 | <b>DWG. NO.      ST-4</b> | DRAWN BY | KK | 09/24 | CHECKED BY | KK | 09/24 |
| DESIGNED BY  | KK  | 09/24       | <b>DWG. NO.      ST-4</b> |       |                           |          |    |       |            |    |       |
| DRAWN BY   | KK  | 09/24       |                           |       |                           |          |    |       |            |    |       |
| CHECKED BY   | KK  | 09/24       |                           |       |                           |          |    |       |            |    |       |