

FOR CURB AND GUTTER DETAIL  
REFER TO THE LATEST SPPWC

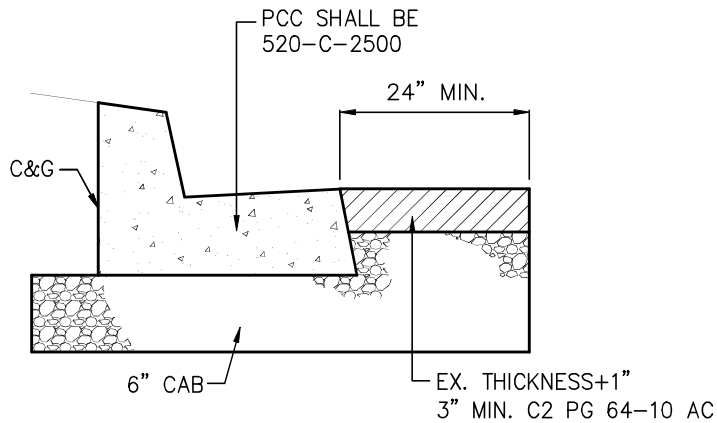

NOTES:

1. 1/2 IN. EXPANSION JOINTS SHALL BE PLACED EVERY 60 FT. WEAKENED PLANE JOINTS PLACED EVERY 20 FT.
2. BASE SHALL BE CRUSHED AGGREGATE BASE (CAB) PER THE "SPPWC" LATEST EDITION.
3. PCC SHALL BE 520-C-2500 PER "SPPWC" LATEST EDITION.
4. MIN. COMPACTION OF 90% ON SUBGRADE AND 95% ON CAB IS REQUIRED.
5. ALL AC AND PCC TO BE REMOVED SHALL BE SAWCUT AT REMOVAL LIMITS. (MIN 5" SAWCUT.)

DWG NTS

CITY OF GARDENA  
DEPARTMENT OF PUBLIC WORKS

APP. BY:

*Allan Rigg*

*9/16/2024*

CITY ENGINEER

DATE

TITLE:

CURB AND GUTTER

DESIGNED BY	KK	09/24
DRAWN BY	KK	09/24
CHECKED BY	KK	09/24

DWG. NO. ST-8